

# GLASSvent® Windows for Storefront Framing

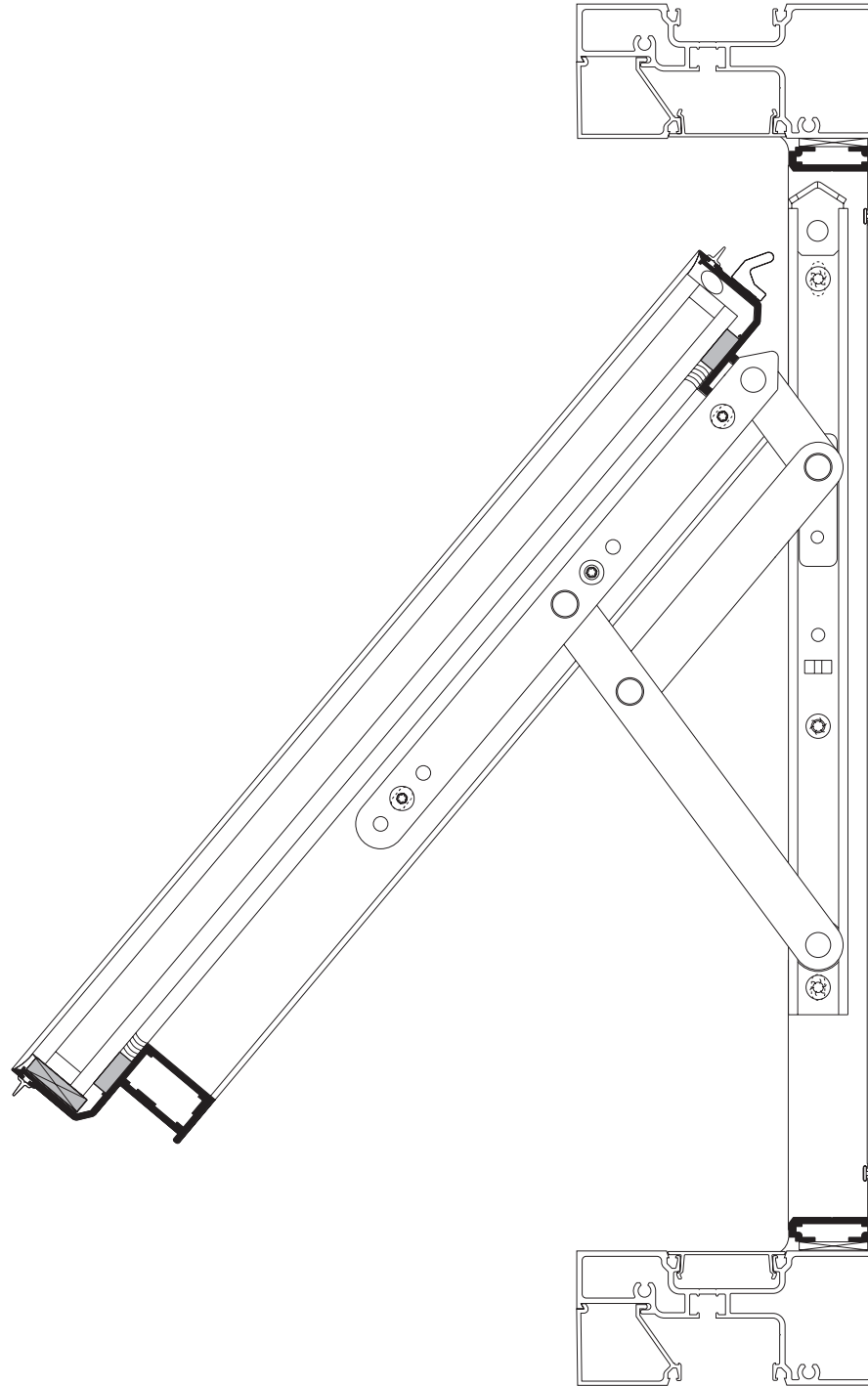

## INSTALLATION INSTRUCTIONS

Laws and building and safety codes governing the design and use of Kawneer products, such as glazed entrance, window, and curtain wall products, vary widely. Kawneer does not control the selection of product configurations, operating hardware, or glazing materials, and assumes no responsibility therefor.

Kawneer reserves the right to change configuration without prior notice when deemed necessary for product improvement.  
© 2008, Kawneer Company, Inc.

These instructions show the general installation sequence and procedure for typical installations. They supplement the shop details and notations on installation and glazing.

| <u>SECTION</u> | <u>PAGE</u> |                           |
|----------------|-------------|---------------------------|
| I              | 3-4         | GENERAL NOTES             |
| II             | 5           | PARTS IDENTIFICATION      |
| III            | 6           | TYPICAL DETAILS           |
| IV             | 7           | GLAZING PROCEDURE         |
| V              | 8-9         | WINDOW FRAME INSTALLATION |
| VI             | 10          | SCREEN INSTALLATION       |
| VII            | 11          | MAINTENANCE INSTRUCTIONS  |

Laws and building and safety codes governing the design and use of Kawneer products, such as glazed entrance, window, and curtain wall products, vary widely. Kawneer does not control the selection of product configurations, operating hardware, or glazing materials, and assumes no responsibility therefor.

Kawneer reserves the right to change configuration without prior notice when deemed necessary for product improvement.  
© 2008, Kawneer Company, Inc.

## A. GENERAL NOTES

### 1. MATERIAL HANDLING

The material must be protected against damage. The following precautions are recommended.

#### a. PROTECTION AND STORAGE

Handle the material carefully. Do not drop from the truck. Stack with adequate separation so the material will not rub together. Store the material off the ground. Protect against the elements and other construction hazards by using a well ventilated covering as required. Remove material from packaging if it is wet or is located in a damp area.

#### b. CHECK MATERIAL

Check all material upon arrival for quantity and to assure against shipping damage. Any visibly damaged material must be noted on the freight bill at the time of receipt. If a claim is required, the receiving party must process a claim with the freight supervisor.

#### c. CLEANING MATERIAL

Cement, plaster, terrazzo, alkaline and acid-based material used to clean masonry are very harmful to finishes and should be removed with water and mild soap **immediately** or permanent staining will occur. A spot test is recommended before any cleaning agent is used.

**NOTE:** If a protective coating is specified, remove it in areas that require sealant.

### 2. CONSTRUCTION NOTES

The following practices are recommended for all window installations:

#### a. REFERENCE SHOP DRAWINGS

Check shop drawings and installation instructions to become thoroughly familiar with the project. The shop drawings take precedence and include specific details for the project. These installation instructions are of a general nature and cover the most common conditions.

#### b. CHECK OPENINGS

Make certain that construction which will receive your material is in accordance with the contract documents. If not, notify the general contractor **in writing** and resolve differences before proceeding with work.

#### c. BENCHMARK LAYOUT

All work should start from benchmarks and/or column centerlines as established by the architectural drawings and the general contractor.

#### d. PLUMB / LEVEL / TRUE

All materials are to be installed plumb, level and true.

- e. ISOLATE ALUMINUM  
Isolate aluminum that directly contacts uncured masonry of incompatible materials with a heavy coat of zinc chromate or bituminous paint.
- f. FASTENING  
“Fastening” means any method of securing one part to another or to adjacent materials.
- g. SEALANTS  
Sealants must be compatible with all materials they contact, including other sealant surfaces. Consult the sealant supplier for recommendations relative to solvent cleaning materials and procedures, compatibility, adhesion, priming, tooling and shelf life.
- h. BUILDING CODES  
Glass and glazing codes governing the design and use of products vary widely. Kawneer does not control the selection of product configurations, operating hardware, or glazing materials, and assumes no responsibilities therefore. It is the responsibility of the owner, specifier, architect, general contractor and the installer to make these selections in strict conformity to all applicable codes.

## B. GENERAL NOTES

### 1. GLASS SIZE INFORMATION

The glass size for the GLASSvent is:

GLASS SIZE = FRAME DIMENSION MINUS 1-1/8"

**NOTE:** For optimum aesthetics application, dark spacer and tinted or high performance glass and seamed edges recommended.

### 2. LIMITATIONS

The GLASSvent is a project-out vent or outswing casement only. Glazing infill options are 1/4" and 1". Maximum size is 5 FT. wide by 3 FT. high for a project-out and 3 FT. wide by 5 FT. high for a casement. Minimum size for each function is 14" wide by 14" high.

### 3. SHIM SPACE INFORMATION













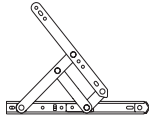





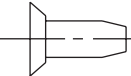

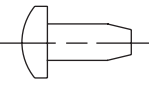
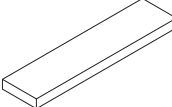
The nominal shim space is 1/8". The maximum shim space is 3/16".

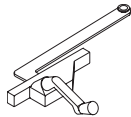
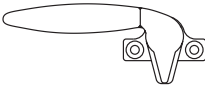
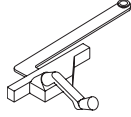
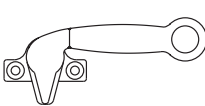
### 4. SURROUNDING METAL

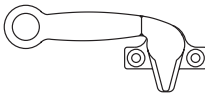
The surrounding framing shall be a minimum thickness of 0.080".

Laws and building and safety codes governing the design and use of Kawneer products, such as glazed entrance, window, and curtain wall products, vary widely. Kawneer does not control the selection of product configurations, operating hardware, or glazing materials, and assumes no responsibility therefor.

Kawneer reserves the right to change configuration without prior notice when deemed necessary for product improvement.  
© 2008, Kawneer Company, Inc.

| ILLUSTRATION  | PART NO. | DESCRIPTION                                       | ILLUSTRATION   | PART NO.           | DESCRIPTION   |
|---|----------|---|--|--------------------|---|
|    | 027874   | INTERIOR GASKET                                   |    | 260410             | REMOVABLE HANDLE FOR AIR CONDITION LOCK   |
|    | 127037   | EXTERIOR GASKET                                   |    | 229101 thru 229107 | 4 - BAR HINGE   |
|    | 127145   | WATER DEFLECTION GASKET                           |    | 028598             | #10 x 1" PAN HEAD THREAD FORMING SCREW TYPE AB  |
|    | 127039   | 1/4" x 7/8" SEMI RIDGED FOAM TAPE for 1/4" INFILL |    | 128401             | #10 x 1" FLAT HEAD THREAD FORMING SCREW TYPE B  |
|    | 127042   | 1/4" x 5/8" SEMI RIDGED FOAM TAPE for 1" INFILL   |    | 128415             | #8 x 1/2" UNDERCUT FLAT HEAD THREAD FORMING SCREW   |
|    | 027313SI | 1/4" x 5/16" x 4-1/8" SILICONE SETTING BLOCK      |    | 128414             | #10 x 7/16" PAN HEAD THREAD FORMING SCREW   |
|    | 027858SI | 1/4" x 1" x 4-1/8" SILICONE SETTING BLOCK         |    | 028337             | 10 x 3/4" FLAT HEAD THREAD FORMING SCREW TYPE B   |
|  | 225405   | LEFT CAM HANDLE                                   |   | 225483             | PIVOT SHOE ROTO OPERATOR  |
|  | 225406   | RIGHT CAM HANDLE                                  |  | 225484             | PIVOT SHOE ROTO OPERATOR  |
|  | 225407   | LEFT CAM HANDLE WITH POLE RING                    |  | 225438             | HOOK BOLT LOCK<br>Optional for Casement. Required for Project-out when Roto Operator is used. |
|  | 225408   | RIGHT CAM HANDLE WITH POLE RING                   |   | 730482             | KEEPER FOR HOOK BOLT LOCK (CASEMENT)  |
|  | 360320   | CUSTODIAL/ AIR CONDITION LOCK                     |   | 229160             | KEEPER FOR HOOK BOLT LOCK (PROJECT-OUT)   |
|  | 225411   | LOCKSTRIKE FOR CAM HANDLES AND CUSTODIAL LOCK     |  |                    |   |
|  | 225471   | POLE/PULL RING                                    |  |                    |   |

Laws and building and safety codes governing the design and use of Kawneer products, such as glazed entrance, window, and curtain wall products, vary widely. Kawneer does not control the selection of product configurations, operating hardware, or glazing materials, and assumes no responsibility therefor.

Kawneer reserves the right to change configuration without prior notice when deemed necessary for product improvement.  
© 2008, Kawneer Company, Inc.

Typical Equations – Infill size = Frame Dimensions minus 1-1/8”.

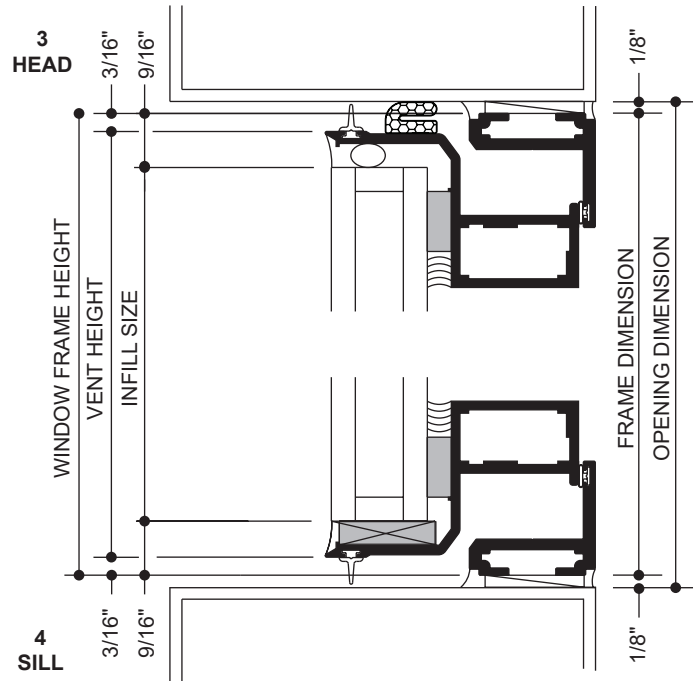
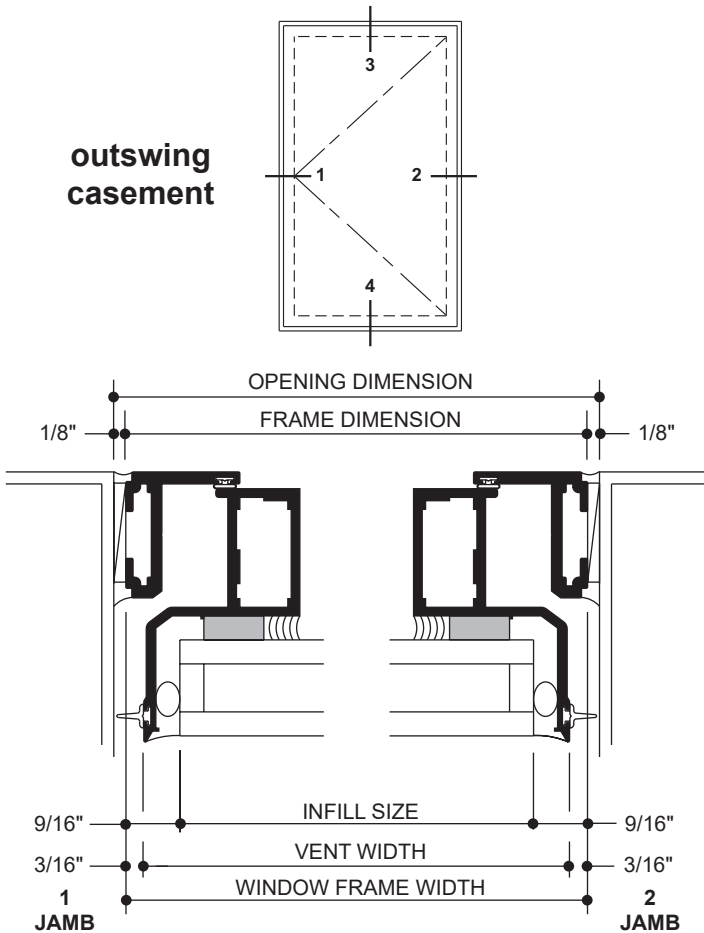
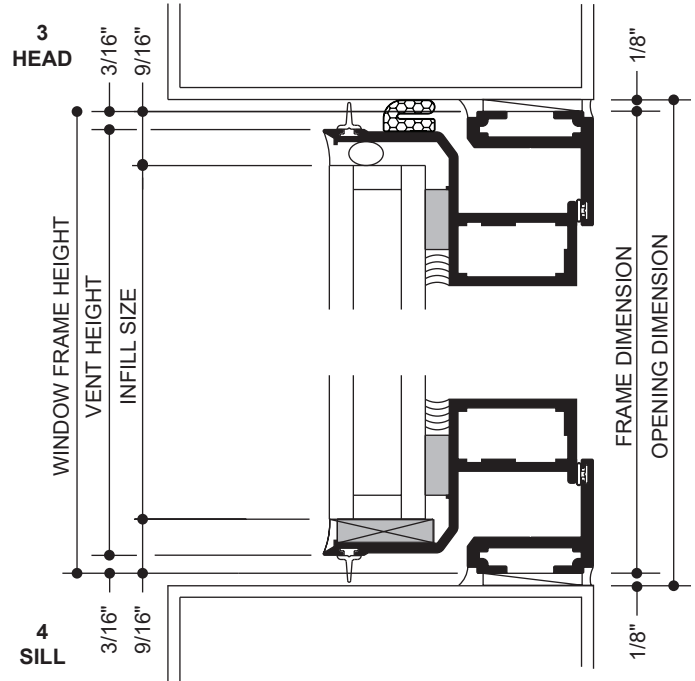
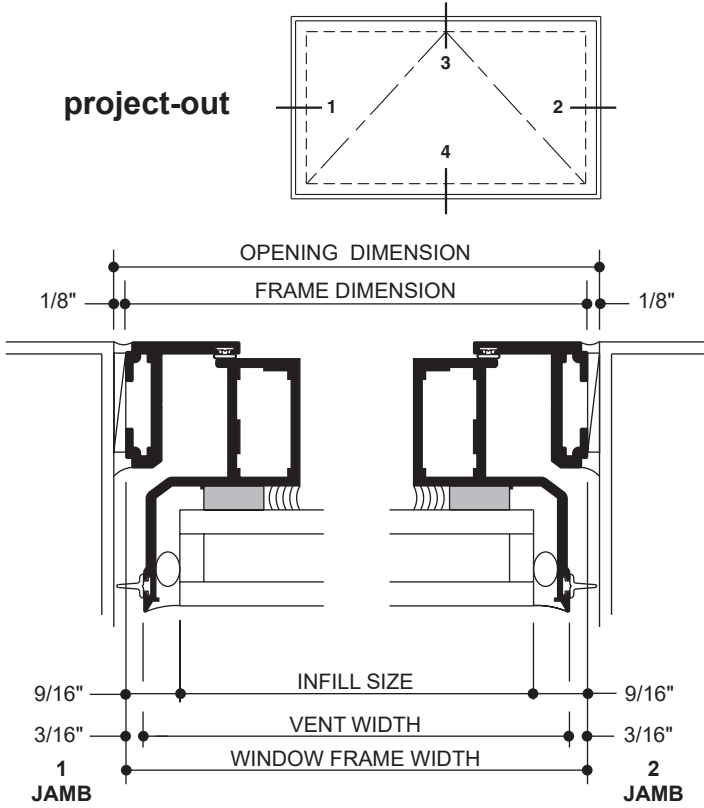

Laws and building and safety codes governing the design and use of Kawneer products, such as glazed entrance, window, and curtain wall products, vary widely. Kawneer does not control the selection of product configurations, operating hardware, or glazing materials, and assumes no responsibility therefor.

Kawneer reserves the right to change configuration without prior notice when deemed necessary for product improvement.  
© 2008, Kawneer Company, Inc.

EC 97904-303

## SECTION IV - GLAZING PROCEDURE

1. Remove the vent from the frame.
2. Clean structural silicone surface of glass and aluminum per manufacturer's recommendations.

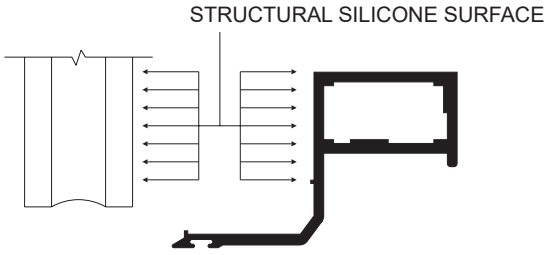

3. Apply Foam Tape\* on jambs. Butt against locator ridges at head/sill and jambs.

\*127042 (1" INFILL)  
\*127039 (1/4" INFILL)

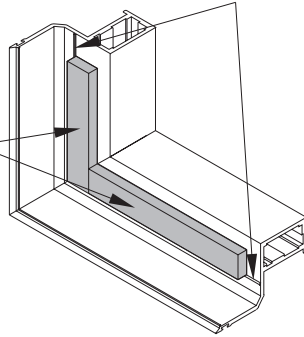

4. Apply Foam Tape\* on head and sill. Butt against locator ridges at head/sill and foam tape at jambs.
5. Place setting blocks at locations shown below.

- a. For Projected windows, place setting blocks at 1/8 pts. or 6" from edge of glass, whichever is greater.

**NOTE:**

1" Setting block (027858SI)  
1/4" Setting block (027313SI)

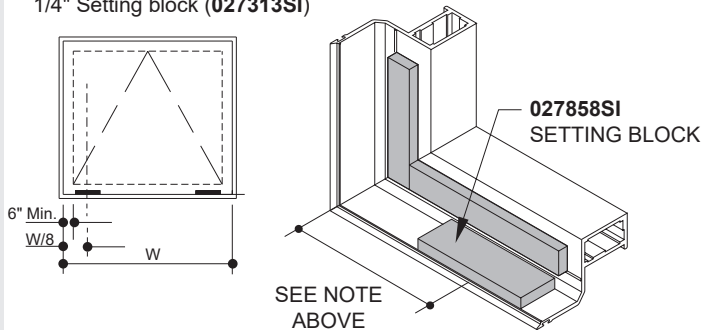

- b. For Casement windows, place setting blocks at Dim. "X". X = W/8 or 2" whichever is greater.

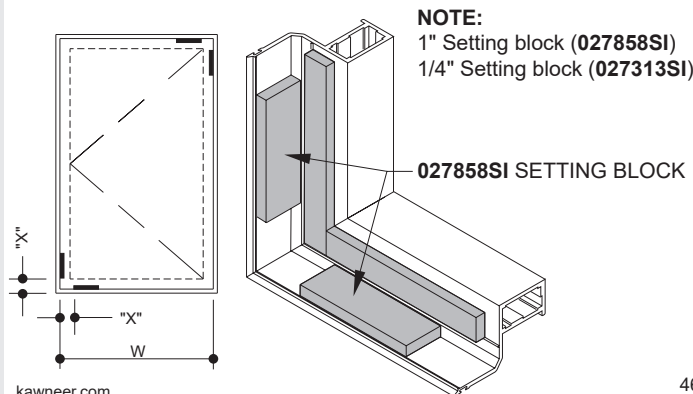

6. Prior to removing protective coating from foam tape, set glass on tape and shim setting blocks as required. Check vent for squareness with a straight edge. The measured diagonal difference should not exceed 1/16".

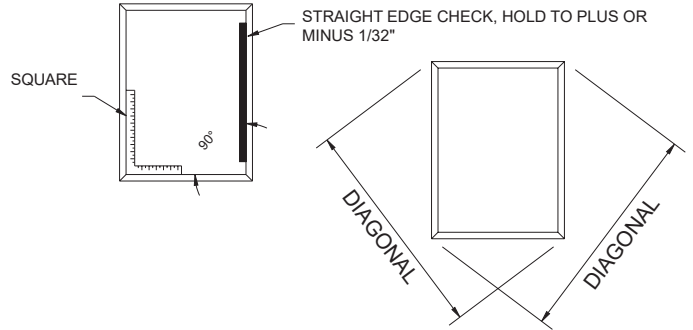

7. Peel protective coating from foam tape. Set glass against tape and press firmly to insure tape adheres to glass and vent.

8. Apply masking tape to areas shown. Apply structural silicone into joint and tool structural silicone completely filling joint. Remove masking tape before silicone skins over.

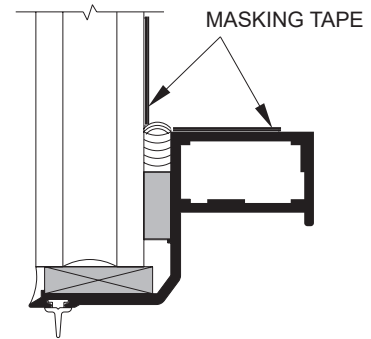

9. Apply 1/2" backer rod (not included) and silicone into joint. Tool silicone flush with glass and metal edges. Remove masking tape.

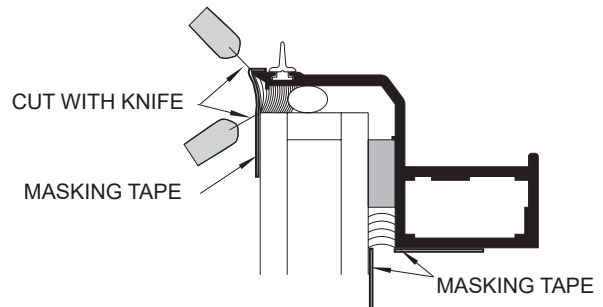

Laws and building and safety codes governing the design and use of Kawneer products, such as glazed entrance, window, and curtain wall products, vary widely. Kawneer does not control the selection of product configurations, operating hardware, or glazing materials, and assumes no responsibility therefor.

Kawneer reserves the right to change configuration without prior notice when deemed necessary for product improvement.  
© 2008, Kawneer Company, Inc.

**WINDOW FRAME PREPARATION**

1. Do not fasten drapery tracks, ceiling supports or convector covers to windows.
2. Fasten window frame into minimum of 0.080" thickness of framing with fastener **028598**.  
**NOTE: 128401 Flat head fastener required behind 4-bar hinges.**  
**(2) 128405 Flat Head Fasteners required 6" apart at Roto Operators.**
3. Minimum anchor spacing: **(Seal over anchor screws)**
  - a. No more than 6" from each side of frame joints.
  - b. No more than 3" from each side of locking points
  - c. No more than 12" O.C. between corners and locking points.
4. Use a 0.201 DIA. - #7 drill bit to make a clearance hole in the window frame.

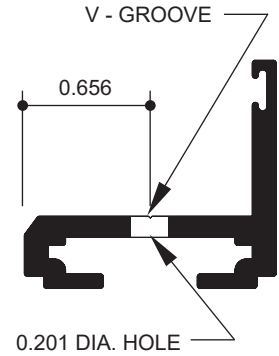

**WINDOW INSTALLATION**

Position the frame per the inset dimension in **TABLE-A**.

**NOTE:** When installing pocket filler **469407** on jamb, use silicone to hold in place.

When other framing systems are used inset GLASSvent frame to maintain a consistant flush glass appearance.

**TABLE-A**

| SYSTEM         | INFILL | INSET DIMENSION | POCKET FILLER |
|----------------|--------|-----------------|---------------|
| TRIFAB 400     | 1/4"   | 0"              | 450087        |
| TRIFAB VG 450  | 1/4"   | 1/4"            | 450087        |
| TRIFAB VG 451  | 1"     | 0"              | 469407        |
| TRIFAB VG 451T | 1"     | 0"              | 469407        |

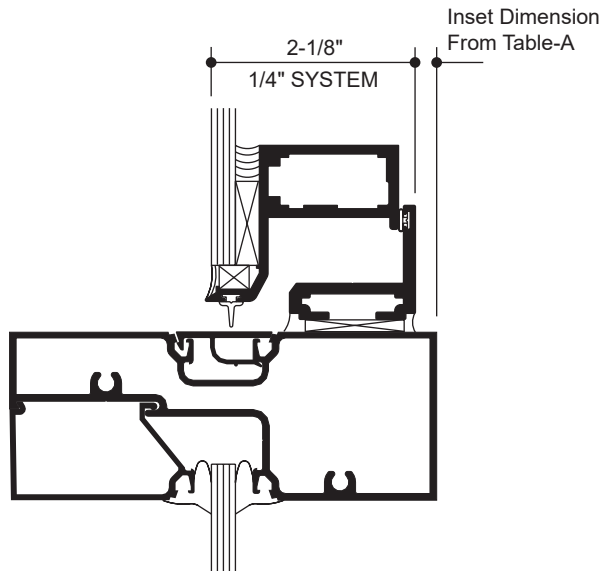

**TRIFAB FRAMING SYSTEMS**

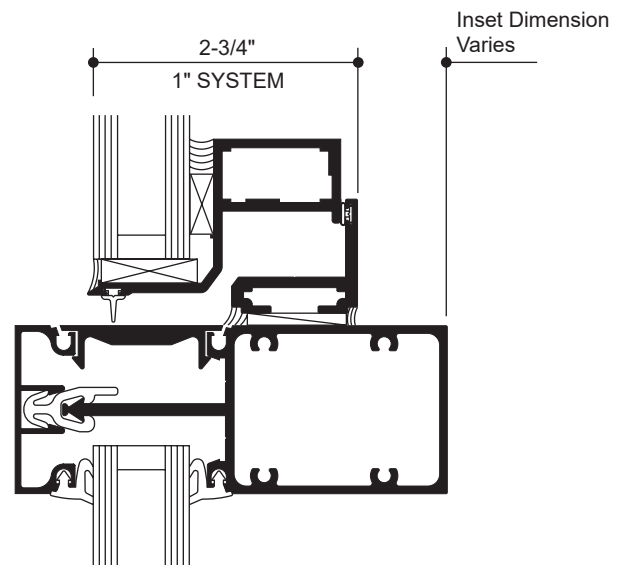

**ALL OTHER FRAMING SYSTEMS  
(Line up glass planes)**

Laws and building and safety codes governing the design and use of Kawneer products, such as glazed entrance, window, and curtain wall products, vary widely. Kawneer does not control the selection of product configurations, operating hardware, or glazing materials, and assumes no responsibility therefor.

Kawneer reserves the right to change configuration without prior notice when deemed necessary for product improvement.  
© 2008, Kawneer Company, Inc.



**WINDOW INSTALLATION (Cont.)**

2. Match drill hole in the surrounding framing with appropriate drill bit.

| SURROUNDING FRAME THICKNESS | DRILL SIZE  |
|-----------------------------|-------------|
| 0.080 to 0.105              | 0.147 (#26) |
| 0.106 to 0.154              | 0.154 (#23) |
| 0.155 to 0.188              | 0.159 (#21) |

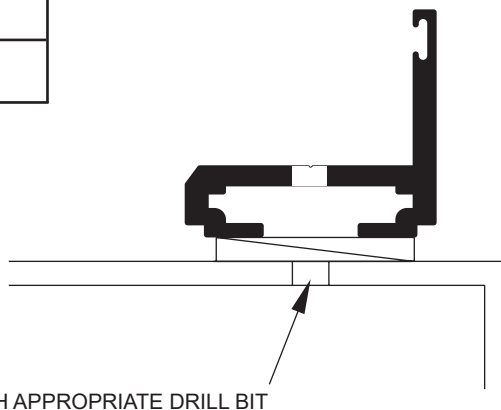

3. Shim as required. For Casement windows, maximum shim space is 3/16". A shim must also be located below the 4 bar hinge and Roto Operators.
4. Install fastener **028598**. Seal over fastener head with sealant.
5. Seal all exposed perimeter joints (between surrounding metal and window frame) with a skinning type sealant.

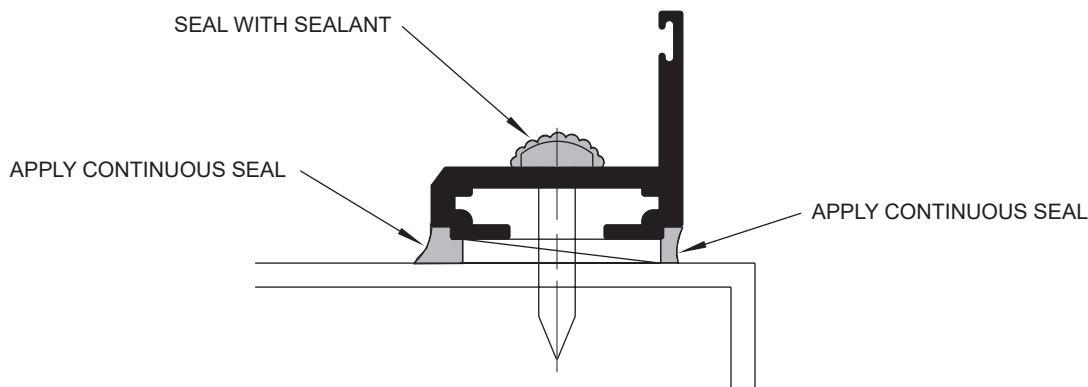

6. Re-install the glazed vent into frame using existing factory drilled holes. Adjust and secure with fixing screw. Care should be taken to not cross thread the fasteners.

Laws and building and safety codes governing the design and use of Kawneer products, such as glazed entrance, window, and curtain wall products, vary widely. Kawneer does not control the selection of product configurations, operating hardware, or glazing materials, and assumes no responsibility therefor.

Kawneer reserves the right to change configuration without prior notice when deemed necessary for product improvement.  
© 2008, Kawneer Company, Inc.

## PROJECT-OUT SCREENS WITH WICKETS

1. Attach screen "J" clips to frame at the four corners of the vent using screws from the screen clip package.
2. Install screens by setting pins onto screen clips.

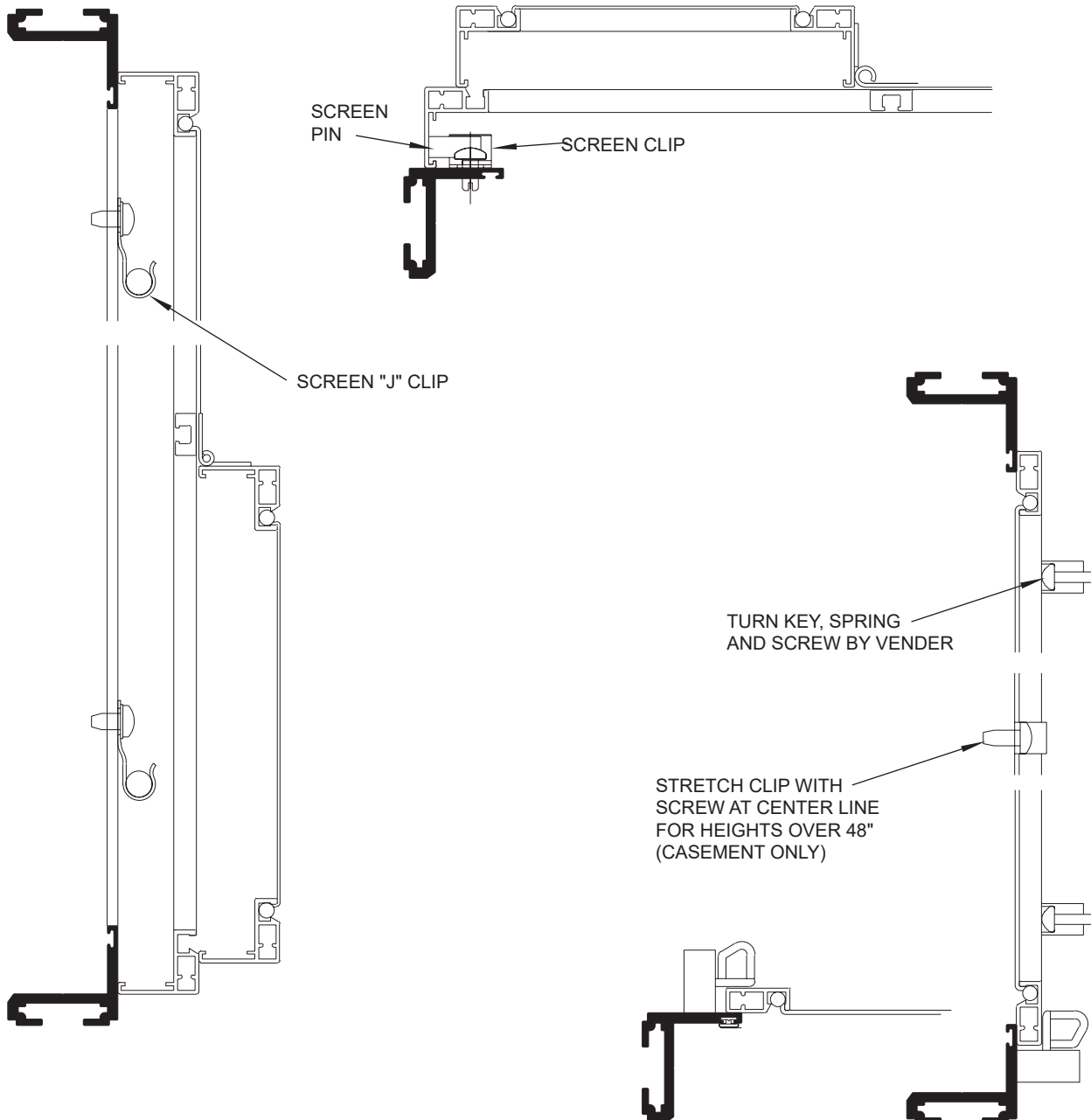

## FLAT SCREENS FOR PROJECT-OUT & OUTSWING CASEMENT WINDOWS WITH ROTO OPERATORS.

1. Attach screen turn key and spring with screw provided in the screen package.
2. Install screens by twisting the turn keys.

Laws and building and safety codes governing the design and use of Kawneer products, such as glazed entrance, window, and curtain wall products, vary widely. Kawneer does not control the selection of product configurations, operating hardware, or glazing materials, and assumes no responsibility therefor.

Kawneer reserves the right to change configuration without prior notice when deemed necessary for product improvement.  
© 2008, Kawneer Company, Inc.

**4- Bar Hinge Linkages**

Check annually for undue wear.  
Clean track of any debris and apply a light machine oil to the track and pivot points. Adjust friction shoe as required.

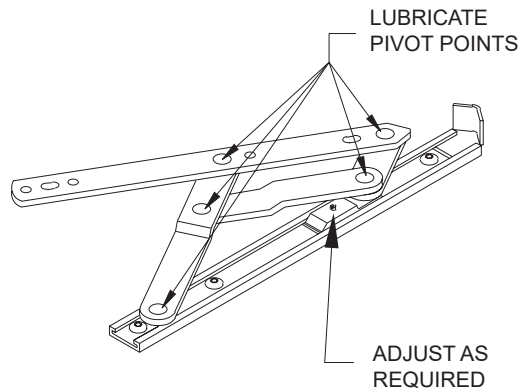

**Deflection Stops**

These are factory installed and adjusted.  
To increase compression on the weather seals loosen the two fasteners in the frame part and slide the stop to the interior. Care must be taken to assure no loss of engagement with the mating ventilator part.

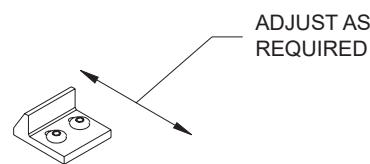

**Multi-point Locks**

(Optional on Outswing Casement Windows.)  
They may operate up to three locking points in the lock jamb.  
Check annually for undue wear. Lubricate as required with **LUBRIPLATE #105** grease or equal. (Kawneer **Part #385112**).

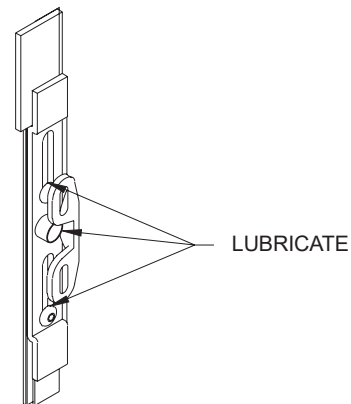

**Hook Bolt Lock**

(Optional for Outswing Casement Windows and Required for Project-out Windows.) It is supplied with Pivot Shoe Roto Operators. To adjust, loosen the two fasteners and move the keeper up or down as required.

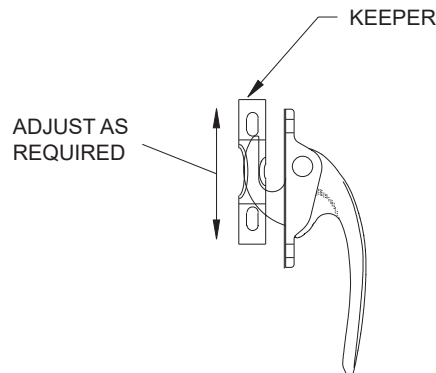

**Pivot-shoe Roto-operators**

These operators are sealed and do not require lubrication.

Laws and building and safety codes governing the design and use of Kawneer products, such as glazed entrance, window, and curtain wall products, vary widely. Kawneer does not control the selection of product configurations, operating hardware, or glazing materials, and assumes no responsibility therefor.

Kawneer reserves the right to change configuration without prior notice when deemed necessary for product improvement.  
© 2008, Kawneer Company, Inc.



KAWNEER COMPANY, INC.  
TECHNOLOGY PARK/ATLANTA  
555 GUTHRIDGE COURT  
NORCROSS, GEORGIA 30092